

IGBT Module

Sixpack

Short Circuit SOA Capability
Square RBSOA

$I_{C25} = 29\text{ A}$
 $V_{CES} = 1200\text{ V}$
 $V_{CE(sat) \text{ typ.}} = 2.5\text{ V}$

Preliminary data

Part name (Marking on product)

MWI 30-12E6K

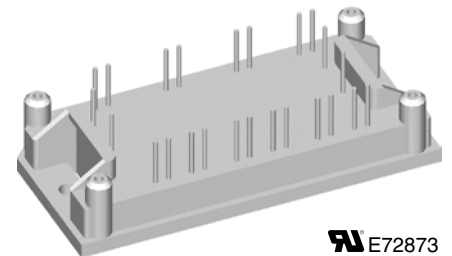
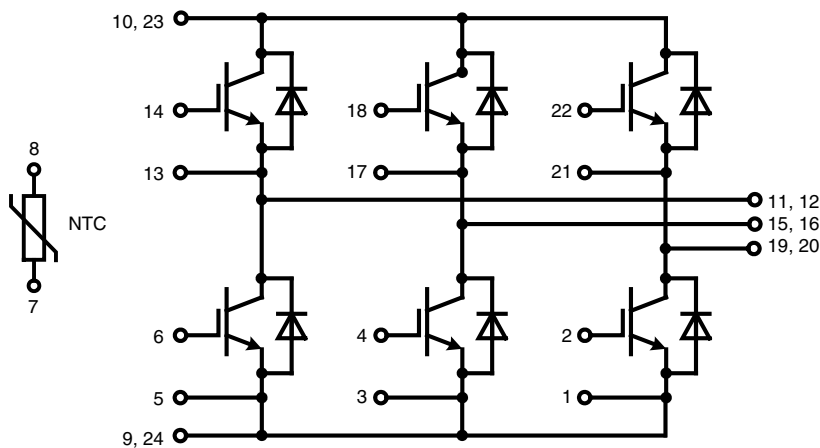

E72873

Pin configuration see outlines.

Features:

- SPT IGBTs
 - low saturation voltage
 - positive temperature coefficient for easy paralleling
 - fast switching
 - short tail current for optimized performance also in resonant circuits
- HiPerFRED™ diode:
 - fast reverse recovery
 - low operating forward voltage
 - low leakage current
- Industry Standard Package
 - solderable pins for PCB mounting
 - isolated copper base plate

Application:

- AC drives
- UPS
- Welding

Package:

- UL registered
- Industry standard E1-pack

IGBTs						
Symbol	Definitions	Conditions	Ratings			Unit
			min.	typ.	max.	
V_{CES}	collector emitter voltage	$T_{VJ} = 25^{\circ}\text{C to } 150^{\circ}\text{C}$			1200	V
V_{GES}	max. DC gate voltage	continuous			± 20	V
V_{GEM}	max. transient collector gate voltage	transient			± 30	V
I_{C25}	collector current	$T_C = 25^{\circ}\text{C}$			29	A
I_{C80}		$T_C = 80^{\circ}\text{C}$			21	A
P_{tot}	total power dissipation	$T_C = 25^{\circ}\text{C}$			130	W
$V_{CE(sat)}$	collector emitter saturation voltage	$I_C = 20\text{ A}; V_{GE} = 15\text{ V}$			2.5 2.9	V V
$V_{GE(th)}$	gate emitter threshold voltage	$I_C = 0.6\text{ mA}; V_{GE} = V_{CE}$	4.5		6.5	V
I_{CES}	collector emitter leakage current	$V_{CE} = V_{CES}; V_{GE} = 0\text{ V}$			0.6	1 mA mA
I_{GES}	gate emitter leakage current	$V_{CE} = 0\text{ V}; V_{GE} = \pm 20\text{ V}$			200	nA
C_{ies}	input capacitance	$V_{CE} = 25\text{ V}; V_{GE} = 0\text{ V}; f = 1\text{ MHz}$			1180	pF
$Q_{G(on)}$	total gate charge	$V_{CE} = 600\text{ V}; V_{GE} = 15\text{ V}; I_C = 20\text{ A}$			100	nC
$t_{d(on)}$	turn-on delay time	inductive load $V_{CE} = 600\text{ V}; I_C = 20\text{ A}$ $V_{GE} = \pm 15\text{ V}; R_G = 56\ \Omega$				
t_r	current rise time					
$t_{d(off)}$	turn-off delay time					
t_f	current fall time					
E_{on}	turn-on energy per pulse					
E_{off}	turn-off energy per pulse					
I_{CM}	reverse bias safe operating area	RBSOA; $V_{GE} = \pm 15\text{ V}; R_G = 56\ \Omega$ $L = 100\ \mu\text{H};$ clamped induct. load $V_{CEmax} = V_{CES} - L_S \cdot di/dt$	$T_{VJ} = 125^{\circ}\text{C}$		45	A
t_{SC} (SCSOA)	short circuit safe operating area	$V_{CE} = 900\text{ V}; V_{GE} = \pm 15\text{ V};$ $R_G = 56\ \Omega;$ non-repetitive	$T_{VJ} = 125^{\circ}\text{C}$		10	μs
R_{thJC}	thermal resistance junction to case	(per IGBT)			0.95	K/W
R_{thCH}	thermal resistance case to heatsink	(per IGBT)			0.35	K/W

Diodes						
Symbol	Definitions	Conditions	Maximum Ratings			Unit
			min.	typ.	max.	
V_{RRM}	max. repetitive reverse voltage				1600	V
I_{F25}	forward current	$T_C = 25^{\circ}\text{C}$			24	A
I_{F80}		$T_C = 80^{\circ}\text{C}$			16	A
Symbol	Conditions	Characteristic Values				Unit
		min.	typ.	max.		
V_F	forward voltage	$I_F = 20\text{ A}$	$T_{VJ} = 25^{\circ}\text{C}$ $T_{VJ} = 125^{\circ}\text{C}$	2.6 2.0	2.9	V V
I_{RM}	max. reverse recovery current	$V_R = 600\text{ V}; I_F = 20\text{ A}$ $di_F/dt = -400\text{ A}/\mu\text{s}$	$T_{VJ} = 100^{\circ}\text{C}$	18		A
t_{rr}	reverse recovery time			130		ns
R_{thJC}	thermal resistance junction to case	(per diode)	$T_{VJ} = 25^{\circ}\text{C}$		1.6	K/W
R_{thCH}	thermal resistance case to heatsink	(per diode)			0.55	K/W

Temperature Sensor NTC

Symbol	Definitions	Conditions	Ratings			Unit
			min.	typ.	max.	
R_{25}	<i>resistance</i>	$T_C = 25^\circ\text{C}$	4.45	4.7	5.0	k Ω
$B_{25/85}$				3510		K

Module

Symbol	Definitions	Conditions	Ratings			Unit
			min.	typ.	max.	
T_{VJ}	<i>operating temperature</i>		-40		125	$^\circ\text{C}$
T_{VJM}	<i>max. virtual junction temperature</i>				150	$^\circ\text{C}$
T_{stg}	<i>storage temperature</i>		-40		125	$^\circ\text{C}$
V_{ISOL}	<i>isolation voltage</i>	$I_{ISOL} \leq 1 \text{ mA}; 50/60 \text{ Hz}$			2500	V~
M_d	<i>mounting torque</i>	(M4)	2.0		2.2	Nm
d_s	<i>creep distance on surface</i>		12.7			mm
d_A	<i>strike distance through air</i>		12.7			mm
Weight				40		g

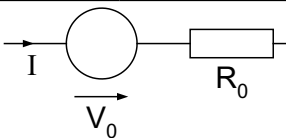
Equivalent Circuits for Simulation

Ratings

Symbol	Definitions	Conditions	min.	typ.	max.	Unit
V_0	<i>IGBT</i>	$T_{VJ} = 125^\circ\text{C}$		1.1		V
R_0				83		m Ω
V_0	<i>free wheeling diode</i>	$T_{VJ} = 125^\circ\text{C}$		1.45		V
R_0				38		m Ω

Outline Drawing

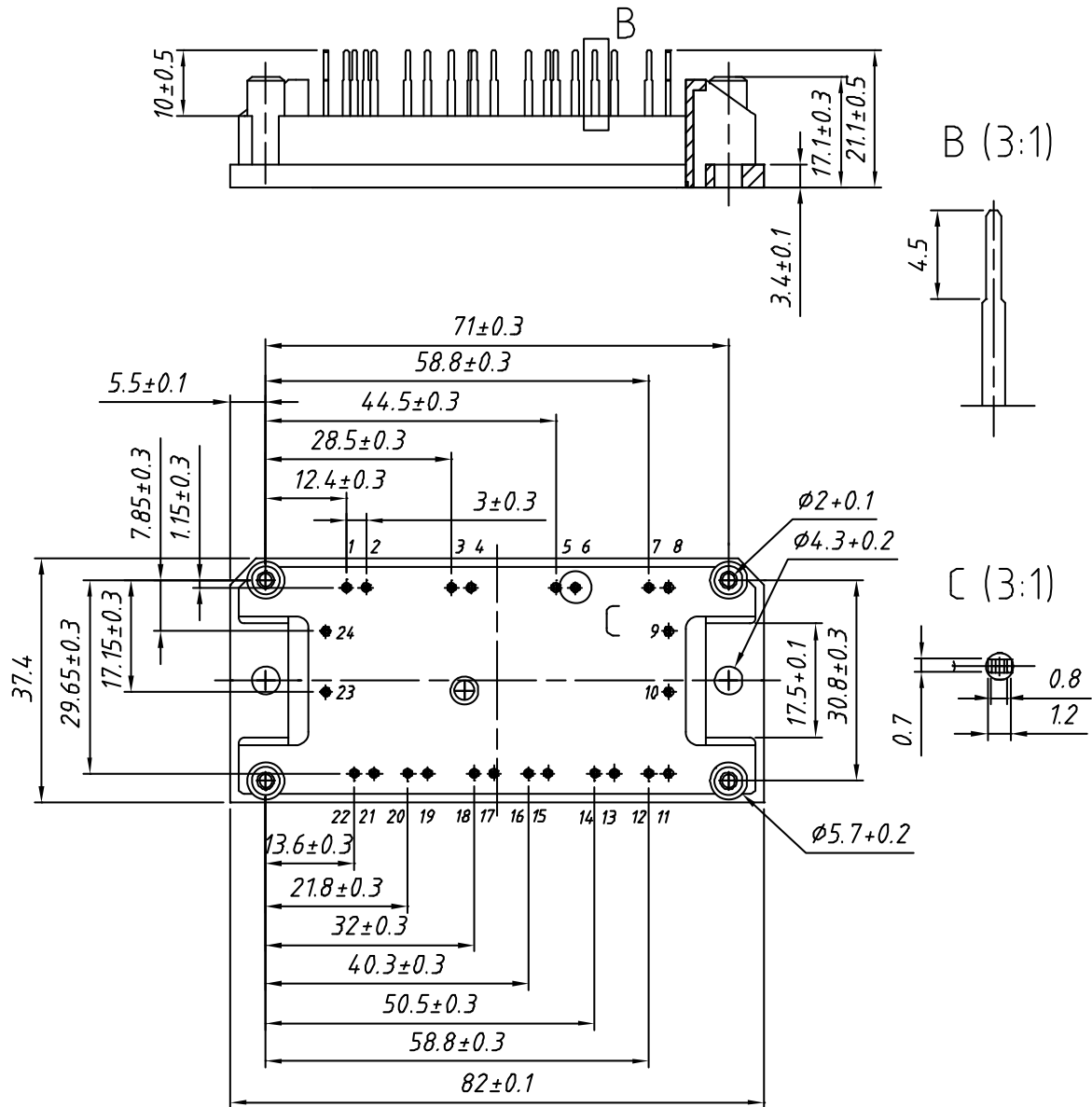
Dimensions in mm (1 mm = 0.0394")



Product Marking

Ordering	Part Name	Marking on Product	Delivering Mode	Base Qty	Ordering Code
Standard	MWI 30-12E6K	MWI30-12E6K	Box	10	500 138